

interceptors

HL-SERIES FOR LARGE VESSELS



HUMPHREE®

Trim and stabilisation systems

HL-Series

FOR
**LARGE
VESSELS**

Our new HLS (Humphree Large Series) are built for large and heavy vessels. This interceptor is designed for continuous operation with the ability to service without docking. The HLS blade has a powerful +100mm stroke length. Like most Humphree interceptors, the HLS can be custom shaped to suit almost any vessel. Typical vessel size, 50 to 150m.



POWERFUL +100 MM STROKE LENGTH

BUREAU VERITAS APPROVED
THROUGH-HULL DESIGN

AVAILABLE SIZES: 800MM – 1500MM

STROKE LENGTH: +100MM

SERVO UNIT: SU530

MOUNTING PLATES: INTEGRATED IN INTERCEPTOR STRUCTURE

TRANSOM THICKNESS: 8-32MM (STEEL, ALUMINIUM)

Powered by Servo unit SU552

Fin rotational speed:	Up to 90°/s
Communication:	HCS5 Integrated
Possible rotation:	360°
Motor:	Brushless Servo motor
Power supply:	24-32V DC
Weight:	52kg
Max peak power consumption:	5kW

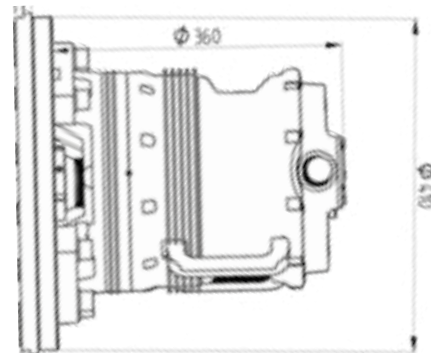

The premium choice

www.humphree.com

FOR YOUR CLOSEST HUMPHREE REPRESENTATIVE

Humphree AB • Grimboåsen 16 • 417 49 Göteborg SWEDEN
+46 31 744 35 77 • humphree@humphree.com